

# Large and High Voltage Motors

Bespoke construction to your needs

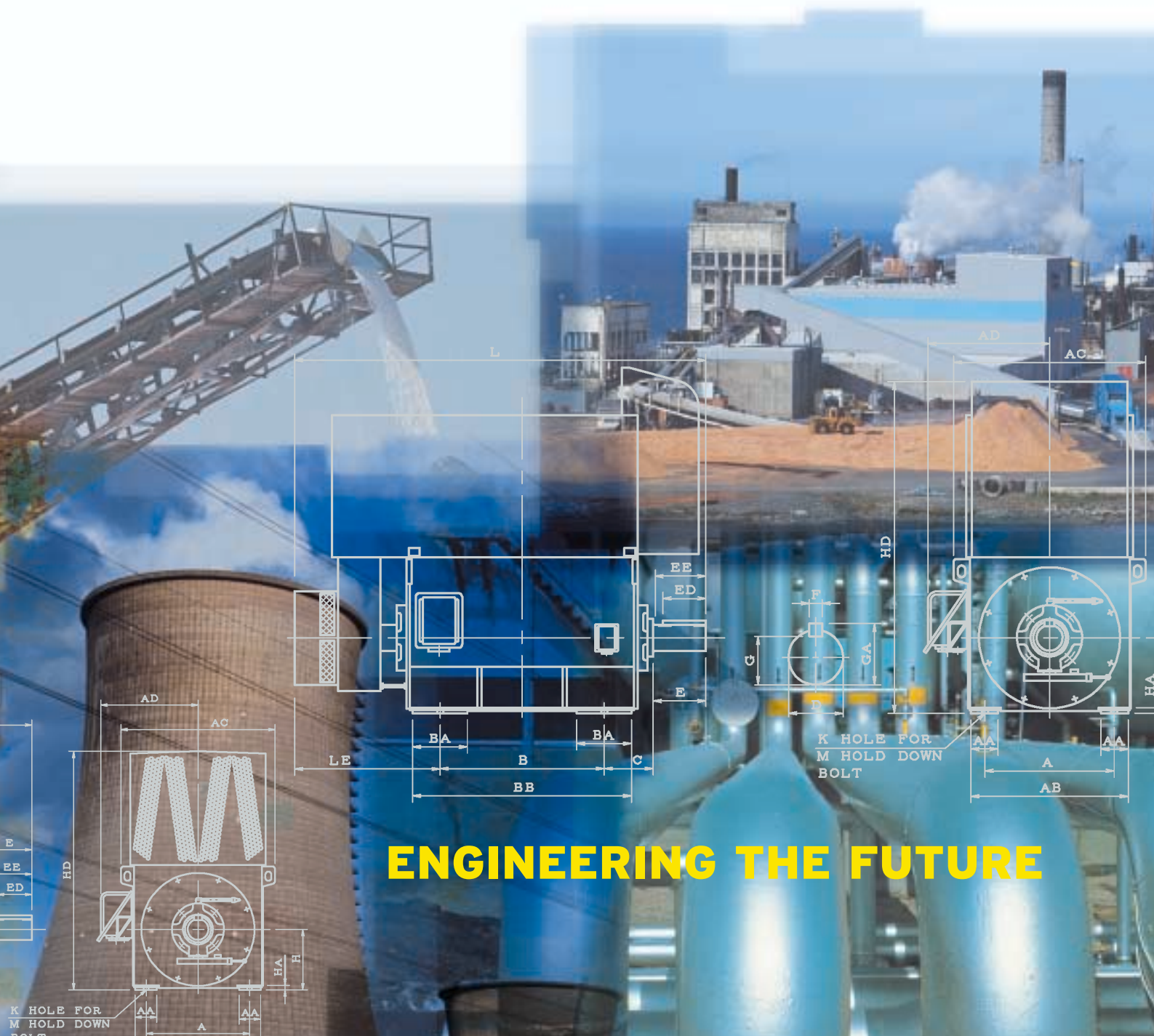

**ENGINEERING THE FUTURE**



2

### TECO MOTOR PRODUCTS

- Low voltage induction motors - IEC and NEMA
- High voltage induction motors
- Inverters
- Eddy current variable speed drives
- Drip proof motors - LV and HV
- DC motors
- Synchronous motors
- Vertical hollow shaft motors
- Hazardous area motors
- High efficiency motors
- Brake motors
- Stepper motors
- Switchgear

### TECO PUBLICATIONS AVAILABLE

- Product overview
- Advantage IEC/Advantage+ high and premium efficiency cast iron motors
- Advantage Lite Aluminium motors
- Advantage Lite Brake motors
- Open Advantage drip proof motors
- Low voltage (AEJC)
- High voltage motors (AEJK)
- Large and High Voltage motors
- Slip ring motors (AEEQ-AEJS)
- Advantage Guardian range - high temperature resistant motors
- Minicon palm drive
- Minicon+ IP65 drive
- Speecon 7200JA variable speed drives
- Speecon 7200MA variable speed drives
- Speecon 7200GA variable speed drives
- Optim 2000 variable speed drives

# Large and H

### LARGE AND HIGH VOLTAGE MOTOR RANGE FROM TECO

TECO's position as a world leader in the design and manufacturing of large induction motors is secured by an unfailing commitment to engineering excellence and technological innovation. For a half a century TECO motors have been recognized as industry leaders in dependability and quality.

### AVAILABLE IN BOTH IEC AND NEMA FRAMES AND SPECIFICATIONS

Voltage Options:

- Low voltage to 750Kw (<690V)
- 3.3kV from 75kW
- 6.6kV from 110kW
- 11kV from 250kW
- 13.2kV from 500kW

Mounting Options:

- Vertical or Horizontal
- Foot and/or flange configurations

Enclosures:

- TEFC = Totally Enclosed Fan Cooled (IC411)
- TECACA = Totally Enclosed, Closed Air Circuit, Air Cooled (IC611)
- TECACW = Totally Enclosed, Closed Air Circuit, Water Cooled (IC81W)
- ODP = Open Dripproof (IC01)
- WPI = NEMA 1 Weatherprotected (IC01)
- WP2 = NEMA 2 Weatherprotected (IC01)



# High Voltage Motors

## CASE STUDY



### APPLICATION

Crown Series motors are custom designed to each customer's specific application. Because of their design versatility and high operating efficiencies, Crown Series motors are the logical choice for a multitude of industries including oil and gas, petro-chemical, pulp and paper, electric utility, water and waste water, marine, steel, mining and air separation.

Typical application of Crown Series motors include agitators, blowers, boring mills, pumps, conveyors, crushers, fans, and many more.



### TILCON QUARRY, SKIPTON, UK

In 1999 TECO-Westinghouse was awarded the contract to supply, test and commission motors and drives to operate crushers at the UK's most advanced quarry.

The Tilcon Quarry produces up to two million tonnes of limestone a year. We supplied them with two induction motors, including the largest AC variable speed motor in the UK (1000kW 6 pole 690v, TECACA).

We also supplied two 12 pulse cubicalised inverters, rated at 450kW and 1000kW and a 2000kva ONAN 11kv to 690v stepdown/phase shift transformer.

We have project capability experience in the following industry sectors, power generation, petro-chemical, mining, paper and quarrying.

With our widest ever product range TECO-Westinghouse can provide you with motors and drives to cover virtually every project.

## Construction

### WINDING/INSULATION - FORM WOUND V.P.I. CLASS 'F' SYSTEM

The insulation system determines the 'life' of a motor. Motor capacity is influenced by the quality of insulation.

TECO utilises mica tape as its base material, which is impregnated with a special epoxy resin. Impregnation is accomplished by immersion of the completely assembled stator in the special resin using a vacuum pressure cycle. This ensures outstanding resistance to heat, moisture, and chemicals, and guarantees safe operation even under most severe environmental conditions



### STATOR FRAME CONSTRUCTION

Crown Series motors use box frame construction to provide frames that have the mechanical strength and stability to assure years of dependable, economical performance. The fabricated steel frames are braced by heavy steel plate bulkheads and end plates to make the frames both laterally and torsionally stable. End brackets are reinforced to give the bearings rigid support and to minimize bearing stiffness.



### STATOR WINDING BRACING

Bracing rings of insulated steel or epoxy glass yarn are used. Individual coils are lashed to the ring with glass cord. Impregnated felt packers are used between coil sides.

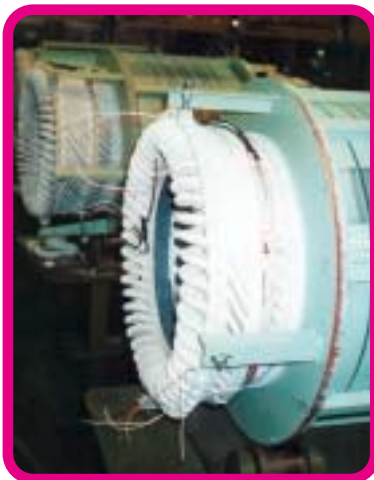

Support of the coil ends is designed to restrain shock and vibration of the coil ends under heavy overload conditions such as those which occur during full voltage starting.

### ROTOR CONSTRUCTION

TECO-Westinghouse induction motor rotors are recognised as the most reliable in the industry, and their high performance standards are a hallmark of the Crown Series motors. Standard construction utilises copper-copper/alloy bars, a time-proven choice for rotor construction because it provides maximum performance and reliability, and high quality silicon steel laminations to minimise losses resulting in high efficiency values.

Connection between rotor bars and end rings are joined together using silver brazing and a "1 shot" brazing technique developed by TECO.

Rotors balanced to 'N' grade as per BSEN and Nema standards.



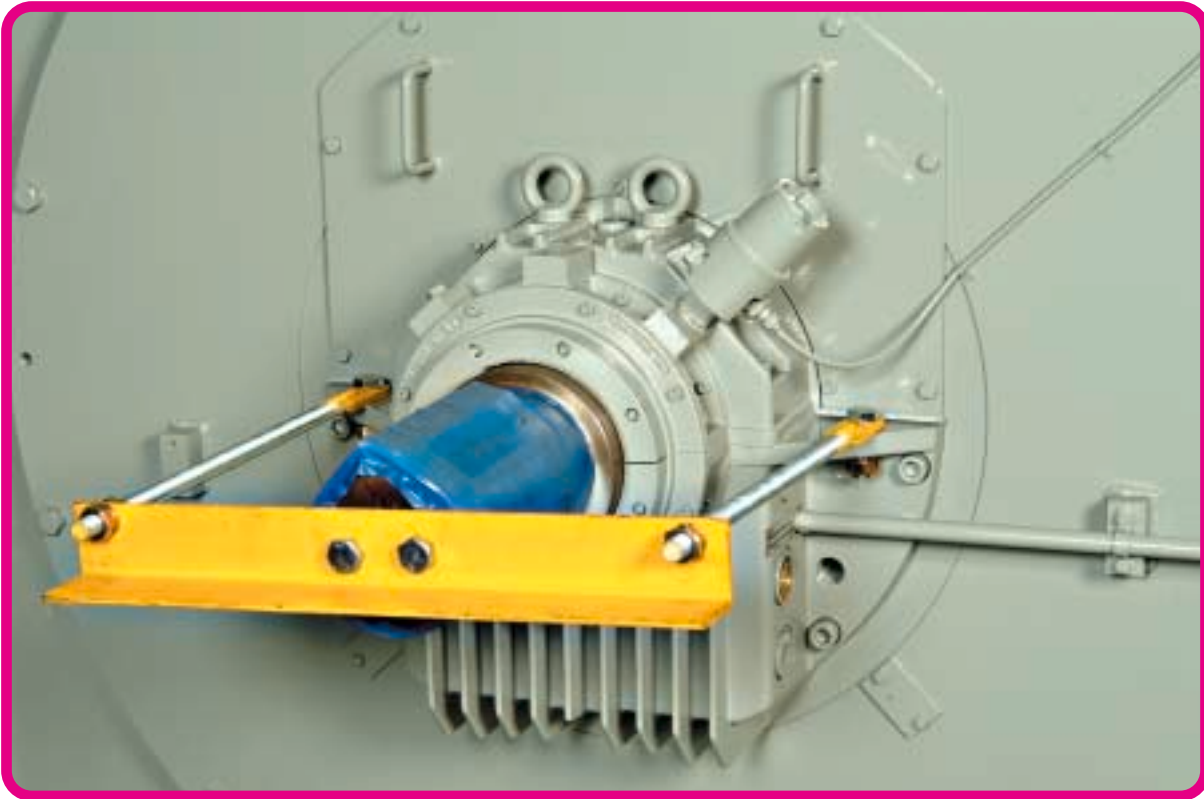

## Bearings

### ADVANCED BEARING SYSTEM FOR RELIABLE PERFORMANCE

The bearing system used in Crown Series Motors has been designed and engineered for continuous, reliable performance and ease of maintenance. Both anti-friction and split-sleeve bearings are offered. Bearing insulation can also be added when required.

### ANTI-FRICTION BEARINGS

Grease lubricated roller bearings are mounted directly into the bores of the endshields. High quality vacuum degassed roller bearings are used for long life and quiet operation.

### SPLIT-SLEEVE BEARINGS

Our split-sleeve bearings are spherically seated and self-aligning, thus providing ease of maintenance in all field conditions. Shaft mounted oil rings transfer the oil from the reservoir to the bearing with gravity feeding back into the reservoir. This bearing system employs a sophisticated sealing system that is designed to eliminate oil leakage along the shaft. The oil ring lubrication process can be easily modified for flood lubrication.



5

## Testing

### 100% ROUTINE TEST

Quality is emphasised at each step as a motor proceeds through each stage of design, assembly and testing.

Each motor is given a routine test as required by BS4999, AS1359 or NEMA MG 1 to determine that it is free from electrical or mechanical defects.

Additional special tests beyond the routine test are available on request. Tests may be witnessed if required.

Figure 1.

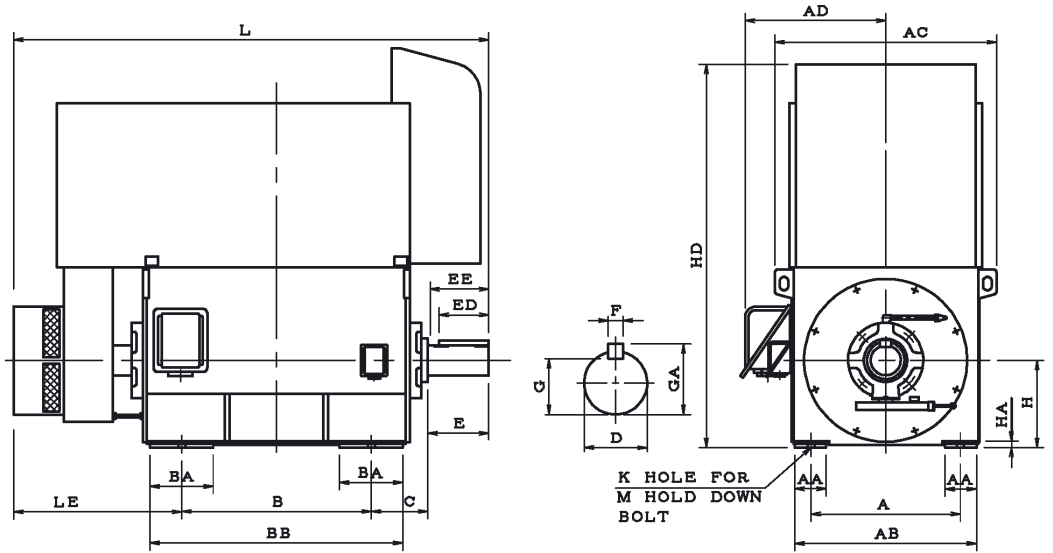

Frame No.	No. of Poles	Fig.	Mounting									AC	AD	H	HA	HD	L	LE	Shaft Extension				Key Size			Frame No.
			A	AA	AB	B	BA	BB	C	K	M								D	E	EE	G	ED	F	GA	
400A	2P	1	800	85	894	800	240	1149	280	35	M24	1120	789	400	36	1996	2173	953	70	140	127	62.5	110	20	74.5	400A
400C	2P	1	800	85	894	1000	240	1349	280	35	M24	1120	789	400	36	1996	2373	953	70	140	127	62.5	110	20	74.5	400C
400C	4P & UP	2	800	85	894	1000	240	1349	280	35	M24	1120	785	400	36	1658	2254	764	110	210	197	100	160	28	116	400C
450A	2P	1	900	85	994	900	280	1318	315	35	M24	1220	839	450	37	2198	2345	990	70	140	127	62.5	110	20	74.5	450A
450A	4P & UP	2	900	85	994	900	280	1324	315	35	M24	1220	835	450	37	1811	2226	801	110	210	197	100	160	28	116	450A
450C	4P	1	900	85	994	1120	280	1544	315	35	M24	1220	835	450	37	2198	2705	1060	110	210	197	100	160	28	116	450C
450C	6P & UP	2	900	85	994	1120	280	1544	315	35	M24	1220	835	450	37	1811	2446	801	110	210	197	100	160	28	116	450C
500A	4P	1	1000	100	1114	1000	280	1418	335	42	M30	1360	895	500	37	2418	2770	1225	125	210	197	114	160	32	132	500A
500A	6P & UP	2	1000	100	1114	1000	280	1418	335	42	M30	1360	895	500	37	1973	2416	871	125	210	197	114	160	32	132	500A
500C	4P	1	1000	100	1114	1250	280	1668	335	42	M30	1360	895	500	37	2418	3020	1225	125	210	197	114	160	32	132	500C
500C	6P & UP	2	1000	100	1114	1250	280	1668	335	42	M30	1360	895	500	37	1973	2666	871	125	210	197	114	160	32	132	500C
560A	4P, 6P	1	1180	100	1244	1120	280	1538	355	42	M30	1490	960	560	51	2764	3030	1305	140	250	237	128	200	36	148	560A
560A	8P & UP	2	1180	100	1244	1120	280	1538	355	42	M30	1490	960	560	51	2211	2646	921	140	250	237	128	200	36	148	560A
560C	6P	1	1180	100	1244	1400	280	1818	355	42	M30	1490	960	560	51	2764	3310	1305	140	250	237	128	200	36	148	560C
560C	8P & UP	2	1180	100	1244	1400	280	1818	355	42	M30	1490	960	560	51	2211	2926	921	140	250	237	128	200	36	148	560C
630A	6P	1	1250	132	1406	1250	355	1714	375	48	M36	1660	1046	630	58	2995	3255	1330	160	300	287	147	250	40	169	630A
630A	8P & UP	2	1250	132	1406	1250	355	1714	375	48	M36	1660	1046	630	58	2416	2871	946	160	300	287	147	250	40	169	630A
630C	6P	1	1250	132	1406	1600	355	2064	375	48	M36	1660	1046	630	58	2995	3605	1330	160	300	287	147	250	40	169	630C
630C	8P & UP	2	1250	132	1406	1600	355	2064	375	48	M36	1660	1046	630	58	2416	3221	946	160	300	287	147	250	40	169	630C
710A	6P	1	1400	180	1488	1400	380	1914	400	48	M36	1782	1087	710	58	3254	3455	1355	160	300	287	147	250	40	169	710A
710A	8P & UP	2	1400	180	1488	1400	380	1914	400	48	M36	1782	1087	710	58	2623	3071	971	160	300	287	147	250	40	169	710A
710B	6P	1	1400	180	1488	1600	380	2114	400	48	M36	1782	1087	710	58	3254	3655	1355	160	300	287	147	250	40	169	710B
710B	8P & UP	2	1400	180	1488	1600	380	2114	400	48	M36	1782	1087	710	58	2623	3271	971	160	300	287	147	250	40	169	710B
710C	8P & UP	2	1400	180	1488	1800	380	2314	400	48	M36	1782	1087	710	58	2623	3855	1355	160	300	287	147	250	40	169	710C
800A	8P & UP	2	1700	180	1790	1600	380	2114	425	55	M42	2084	1238	800	58	3078	3400	1075	180	300	287	165	250	45	190	800A
800B	8P & UP	2	1700	180	1790	1800	380	2314	425	55	M42	2084	1238	800	58	3078	3600	1075	180	300	287	165	250	45	190	800A

Dimensions in mm

NOTES

1. Tolerance of shaft extension diameter D = m6
2. Tolerance of shaft centre height H =  $\frac{H}{10}$  for F#630 & below  $\frac{H}{8}$  for F#710 & up
3. Tolerance of key width F = h9
4. Usable Shaft Length: EE
5. Anti-friction bearings

Figure 2.

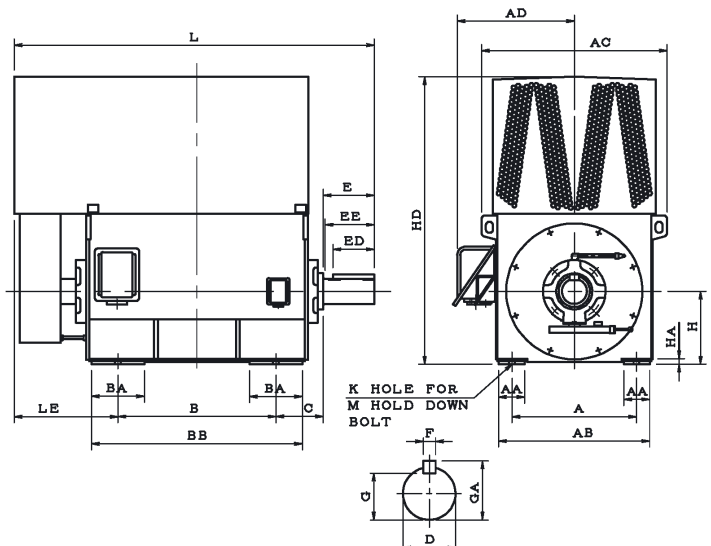
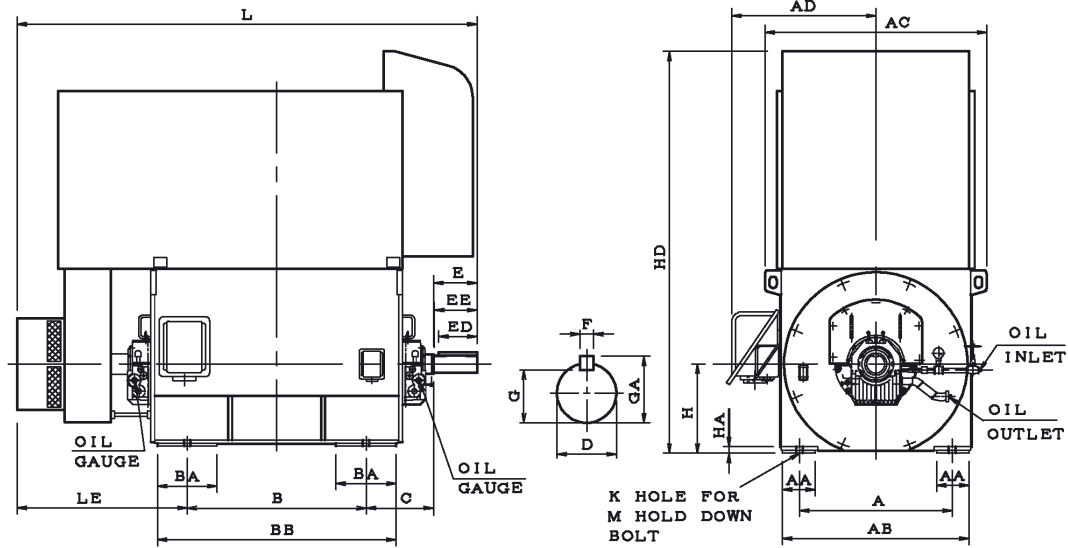

Figure 3.



Frame No.	No. of Poles	Fig.	Mounting									AC	AD	H	HA	HD	L	LE	Shaft Extension				Key Size			Frame No.
			A	AA	AB	B	BA	BB	C	K	M								D	E	EE	G	ED	F	GA	
400D	2P	3	800	85	894	1120	240	1469	375	35	M24	1120	796	400	36	1996	2698	1033	85	170	164	76	140	22	90	400D
450B	2P	3	900	85	994	1000	280	1418	425	35	M24	1220	839	450	37	2198	2665	1070	85	170	164	76	140	22	90	450B
450D	2P	3	900	85	994	1250	280	1668	425	35	M24	1220	839	450	37	2198	3015	1170	85	170	164	76	140	22	90	450D
500B	2P	3	1000	100	1114	1120	370	1532	450	42	M30	1360	899	500	37	2418	3120	1380	85	170	164	76	140	22	90	500B
500D	2P	3	1000	100	1114	1400	370	1812	450	42	M30	1360	899	500	37	2418	3400	1380	95	170	164	86	140	25	100	500D
560C	4P	3	1180	100	1244	1400	280	1818	450	42	M30	1490	960	560	51	2764	3500	1400	140	250	244	128	200	36	148	560C
560D	2P	3	1180	100	1244	1600	405	2006	450	42	M30	1490	964	560	51	2764	3580	1320	110	210	204	100	160	28	116	560D
560D	2P	3	1180	100	1244	1600	405	2006	450	42	M30	1490	964	560	51	2764	3680	1420	110	210	204	100	160	28	116	560D
630A	4P	3	1250	132	1406	1250	355	1714	500	48	M36	1660	1046	630	58	2995	3425	1425	140	250	244	128	200	36	148	630A
630C	4P	3	1250	132	1406	1600	355	2064	500	48	M36	1660	1046	630	58	2995	3825	1425	160	300	294	147	250	40	169	630C
710A	4P	3	1400	180	1488	1400	380	1914	560	48	M36	1782	1087	710	58	3254	3710	1450	180	300	287	165	250	45	190	710A
710B	4P	3	1400	180	1488	1600	380	2114	560	48	M36	1782	1087	710	58	3254	3910	1450	180	300	287	165	250	45	190	710B
800A	6P	3	1700	180	1790	1600	380	2114	560	55	M42	2084	1238	800	58	3702	4000	1540	180	300	287	165	250	45	190	800A
800B	6P	3	1700	180	1790	1800	380	2314	560	55	M42	2084	1238	800	58	3702	4200	1540	180	300	287	165	250	45	190	800B
900A	6P	3	1800	220	1995	1800	430	2310	600	55	M42	2301	1338	900	65	3950	4400	1650	200	350	337	185	280	45	210	900A
900A	8P & UP	4	1800	220	1995	1800	430	2310	600	55	M42	2301	1338	900	65	3293	3865	1115	200	350	337	185	280	45	210	900A

7

Dimensions in mm

Figure 4.

NOTES

1. Tolerance of shaft extension diameter  $D = m6$
2. Tolerance of shaft centre height  $H = \begin{smallmatrix} \text{H} \\ \text{H} \end{smallmatrix}$  for F#630 & below  $\begin{smallmatrix} \text{H} \\ \text{H} \end{smallmatrix}$  for F#710 & up
3. Tolerance of key width  $F = h9$ , of key height  $GD = h11$
4. Usable Shaft Length: EE
5. Sleeve bearings
6. Provision for noncontactive vibration probe, distance of "C" has to be changed:  
F#400-450:C+70, F#500-560: C+80
7. F#500B & Below, self lubrication bearing. All others must be force lubrication.

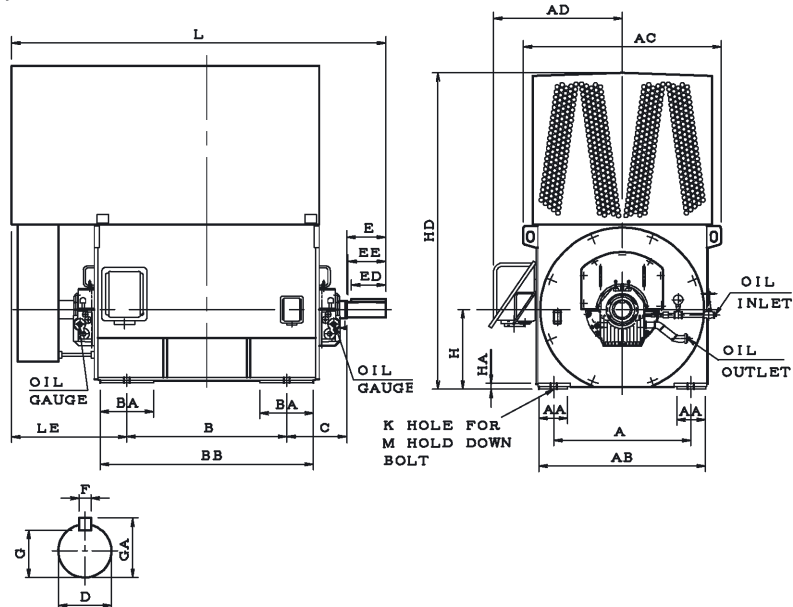

#### UNITED KINGDOM

Teco Electric Europe Limited,  
Teco Building, Marshall Stevens Way,  
Trafford Park, Manchester  
M17 1PP, England, United Kingdom  
Tel: +44 (0)161 877 8025  
www.teco.co.uk

#### GERMANY

Teco-Westinghouse  
Niederlassung Deutschland  
Marktstraße 69  
37441 Bad Sachsa  
Telefon: +49 (0)523 95340

#### SPAIN

Teco Electric Europe Ltd  
C/ Sancho Dávila, 8, 4º F  
28028 Madrid, Spain  
T +34 91 725 1718

#### UNITED STATES

Teco-Westinghouse Motor Co.  
PO Box 227 (78680-0277)  
5100 N-IH35  
Round Rock, Texas 78681, USA  
Tel: +1 512 255 4141  
www.tecowestinghouse.com

#### CANADA

Teco-Westinghouse Motors (Canada)  
Inc., 18060-109 Avenue, Edmonton,  
Alberta T5S 2K2, Canada  
Tel: +1 780 444 8933  
www.twmi.com

#### AUSTRALIA

Teco Australia Pty Ltd  
335-337 Woodpark Road,  
Smithfield, NSW 2164, Australia  
Tel: +61 2 9765 8118  
www.teco.com.au

#### NEW ZEALAND

Teco (New Zealand) Ltd  
Unit 3, 477 Great South Road,  
Penrose, Auckland, New Zealand  
Tel: +64 9 526 8480

#### TAIWAN

Teco Electric & Machinery Co. Ltd  
49 Wu Kong 6 Rd, Wu-Ku Industrial  
Park, Taipei County 248,  
Taiwan, ROC  
Tel: +886 2 8990 1111  
www.teco.com.tw

#### HONG KONG

Tecoson Industrial, Development  
(HK) Co Ltd, Rm 3504-07 Hong  
Kong Plaza, 186-191 Connaught Rd  
West, Hong Kong  
Tel: +852 2858 3220

#### JAPAN

Sankyo Co. Ltd, 4th Floor,  
Maruchin Bldg 1-6-2,  
Hamamatsucho, Minato-Lan,  
Tokyo 105, Japan  
Tel: +81 3 3435 9719

#### SINGAPORE

Teco Electric & Machinery (PTE) Ltd  
18 Chin Bee Drive, Singapore 619865  
Tel: +65 6265 4622  
www.teco.com.sg

#### MALAYSIA

Teco Industry (Malaysia) SDN BHD  
2600 Jalan Perusahaan Baru,  
Kawasan Perusahaan Prai, 13600  
Prai, Penang, Malaysia  
Tel: +60 (0)4 3909908

#### INDONESIA

P.T. Teco Multiguna Elektro  
JL Bandengan Utara No. 83/1-3,  
Jakarta Utara - 14400, Indonesia  
Tel: +62 21 6626065

#### THAILAND

Teco Electric & Machinery (Thai)  
Co. Ltd., 128/1 Soi Watsrivarenoi,  
Moo 7, Bangna - Trad Road Km 18,  
Bangchalong, Bangplee,  
Samuthprakarn 10540, Thailand  
Tel: +662 3371311-20



#### YOUR LOCAL TECO DISTRIBUTOR

**TECO** Westinghouse   
TECO ELECTRIC EUROPE LIMITED

#### TECO ELECTRIC EUROPE LIMITED

Teco Building · Marshall Stevens Way · Trafford Park  
Manchester · M17 1PP · England · United Kingdom  
T +44 (0)161 877 8025 · F +44 (0)161 877 8030  
E enquiries@teco.co.uk

[www.teco.co.uk](http://www.teco.co.uk)

0303/TEE011/ISSUE 2